



180° MARTINI BAR



180° MARTINI BAR AND IT'S CONTENTS

Each 180° Martini Bar comes with the following:

- Curved speed rail for convenient storage of frequently used bottles (packaged separately)
- Curved glass hanging rack underneath the countertop (comes secured to bar)
- Stainless steel waste basket (packaged separately)
- Stainless steel bottle bin (packaged separately)
- Removable cap catcher to hold bottle caps (packaged separately)
- Ice bin with cover (packaged separately)
- Sink with faucet with hot and cold water connections (comes secured to bar)
- Outdoor rated rope lighting (comes secured to bar)
- Two 110 V outlets (comes secured to bar)

PLEASE MAKE SURE THAT EVERYTHING IS INCLUDED INSIDE YOUR BAR BEFORE UNPACKING.

UNPACKING

1. Remove the packaging material surrounding the unit.
2. Use a #2 type Phillips head screwdriver to remove the screws in the five wooden boards securing the bar to the wooden skid.
3. Carefully lift the bar off the skid and set onto level ground. (ONLY lift the bar by the diamond-tread base plate.)

SET UP

The 180° Martini Bar was designed for outdoor use. The quality of stainless steel used in your Martini Bar does not rust or fade. Kalamazoo Outdoor Gourmet® does recommend covering the bar when not in use to help reduce the amount of cleaning needed. Locate the bar on **level and stable** ground.

The 180° Martini Bar includes several accessories that need to be assembled onto the unit.

- The curved speed rail attaches to the main shelf. Simply slide the keyholes on the speed rail over the corresponding supports on the front of the shelf.
- The cap catcher attaches to the rear of the bar underneath the bottle cap remover cutout on the right hand side.
- The ice bin sets into the center opening on the main shelf.
- Plug rope lighting in to one of the 110 V outlets inside the bar.
- Plug the main power cord into an on-site outlet to power bar outlets.

To properly plumb the water lines of your 180° Martini Bar, contact a professional plumber.

- Review the separate manual inside the water filter box for installation and any future replacements of the filter.

Set Up Continued

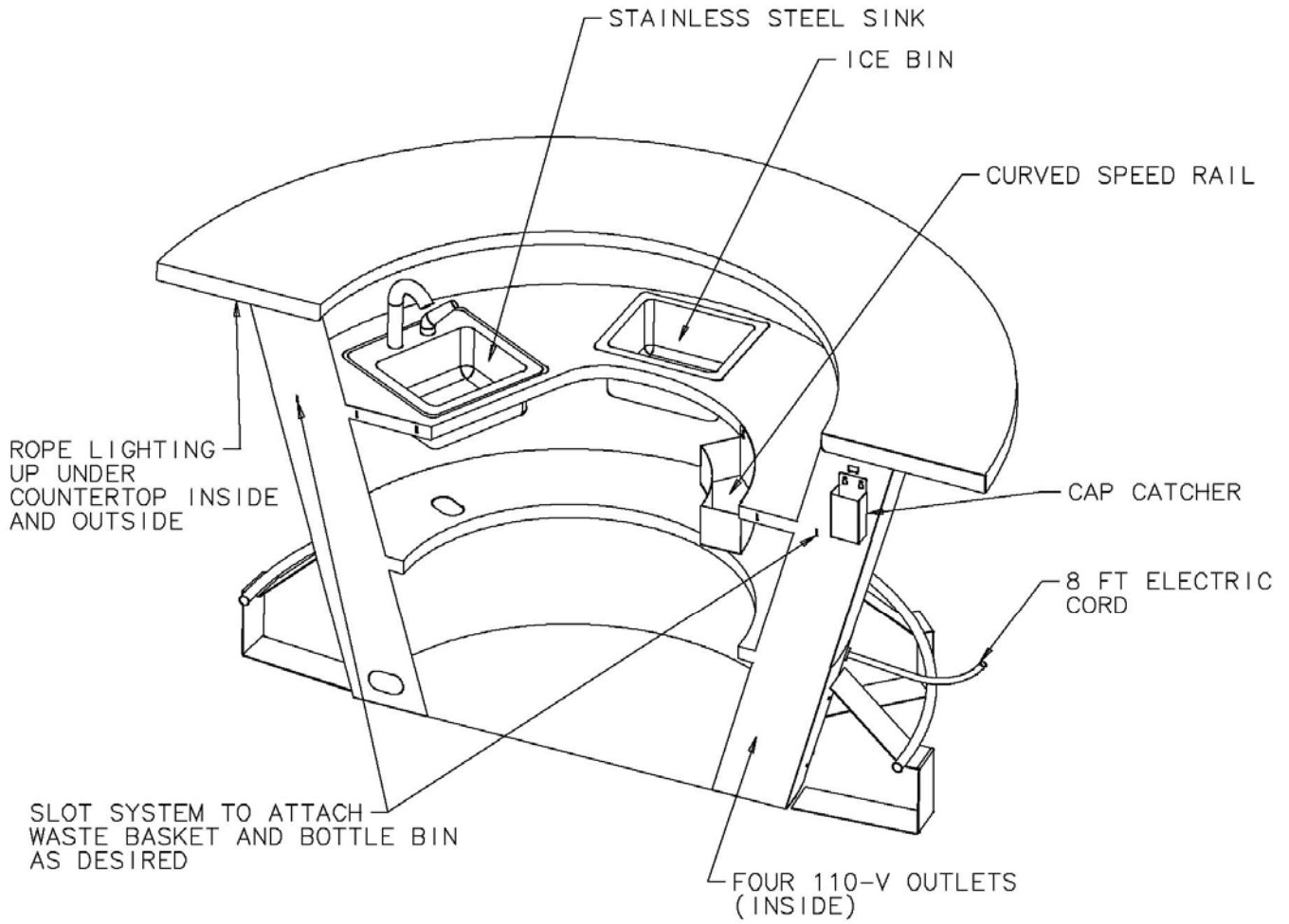

THE 180° MARTINI BAR

Kalamazoo Outdoor Gourmet® is world famous for unique barbeque grills that last a lifetime. We have now expanded our outdoor entertaining product line to include the exquisite 180° Martini Bar.

Our designers were given the task to create an indoor/outdoor bar that would be elegant, fun, and functional. We think that they definitely achieved this goal with the 180° Martini Bar. Each bar has been hand crafted by Kalamazoo Outdoor Gourmet's talented fourth generation metal smiths. Every bar is different. Every bar is one of a kind.

Cleaning stainless steel surfaces. *Stainless steel is non-rusting and non-magnetic.*

Use a warm soap water solution or mildest cleaners (we recommend using stainless steel cleaner, which is available at most hardware or home improvement stores.)

Always rub or scrub in the direction of the grain.

To touch-up minor scratches in the stainless steel, sand the affected surface very lightly, with a gray #7448 Scotch Brite pad in the direction of the grain. (DO NOT use any other pad or brush to clean your 180° Martini Bar.)

We have assembled some drink recipes for you to sample. Enjoy.

THE KALAMAZOO MARTINI

1 ¼ oz. Stolichnaya Vodka
¼ oz. Dom Perignon Champagne

Shake with ice and strain into a chilled glass.

COSMOPOLITAN

1 ¼ oz. vodka
¼ oz. lime juice
¼ oz. Triple sec
¼ oz. Cranberry juice

Shake with crushed ice. Strain into glass. Garnish with lime.

CHOCOLATE MARTINI

1 oz. Vodka
1 oz. Vanilla vodka
1 oz. White crème de cacao
1 splash chocolate liqueur

Cocoa powder the rim of a cocktail glass. Mix ingredients in a shaker over ice, strain into glass. Drop in a small piece of chocolate and a splash of the liqueur.

Shake on ice. Strain into glass.

BREAKFAST MARTINI

2 oz. Gin
½ oz. Triple sec
¼ oz. Freshly squeezed lemon juice
1 spoon light orange marmalade

Shake ingredients with ice and strain into glass. Garnish with orange slice.

MARSALA MARTINI

¾ oz. Dry Marsala
1 oz. Gin
¾ oz. Dry Vermouth

Mix over ice. Strain into sugar rimmed glass.

BACARDI COCKTAIL

1 ½ oz. Light rum
Juice of ½ lime
½ tsp. Grenadine

Shake with ice. Strain into glass.